



TELESCOPIC WHEEL LOADER | TM320 / TM320 WASTEMASTER

Gross power: TM320: 93kW (125hp) | Lift capacity: 3,200kg | Lift height: 5,200mm



STRENGTH YOU CAN RELY ON.

THE TM320 HAS BEEN DESIGNED AND BUILT FROM SCRATCH TO DELIVER THE STRENGTH AND POWER YOU'RE LOOKING FOR IN AN ARTICULATED MACHINE. NO COMPROMISE.

Proven reliability.

- 1** We stress test across a lifetime of cycles to emulate the most arduous digging and dump situations. It's your guarantee of performance over thousands of hours.
- 2** The centrally mounted lift, tilt and extension rams eliminate boom twisting, and are held in place by centrally-mounted keyhole castings for even greater structural integrity.
- 3** At JCB, we make our own hydraulic cylinders, cabs, axles, transmissions and engines – all designed to work in perfect harmony for optimum reliability.
- 4** To provide long-term protection, we dip every cab and various bodywork panels in electrophoretic alloy before painting it.

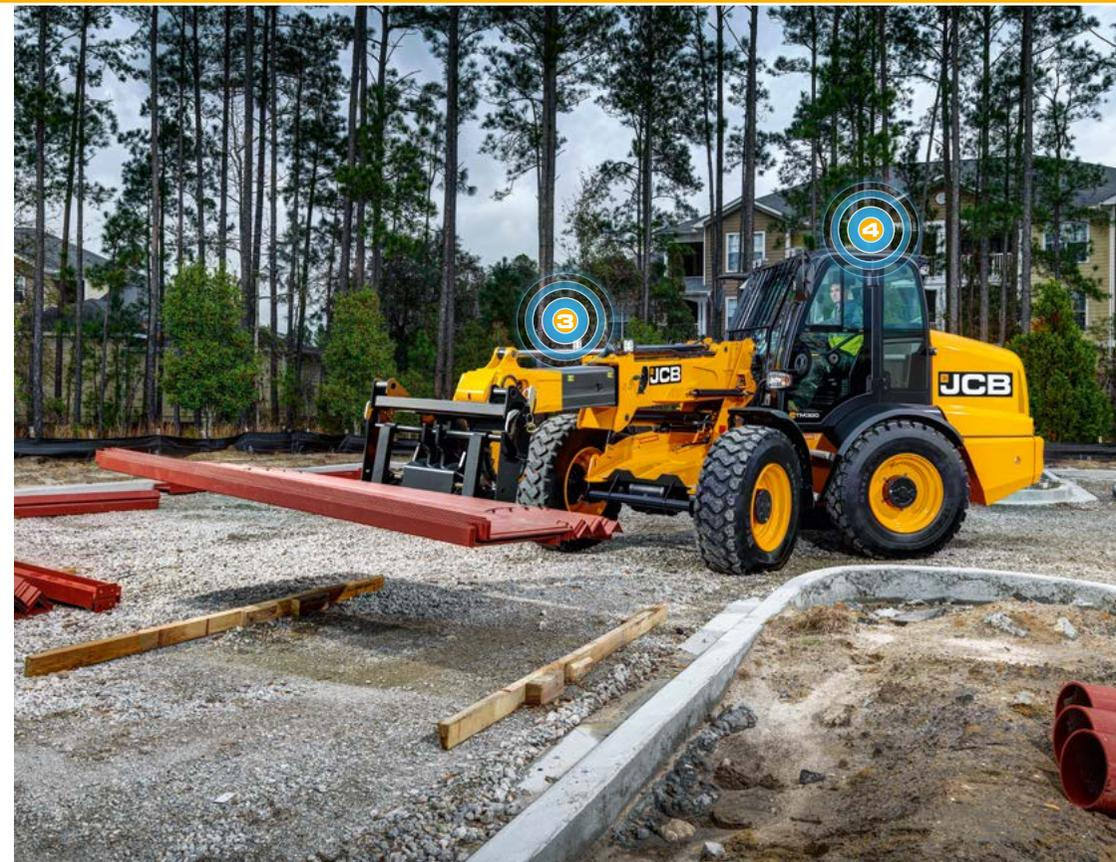

Designed to work hard.

5 A heavy-duty centre joint takes both vertical and horizontal loadings for maximum durability and rigidity.

6 The TM320's tough, inverted U-shaped boom pressing features fully welded closing plates for ultimate strength, and is mounted into a heavy-duty loader tower.

7 The cast rear counterweight helps prevent impact damage. Recessed rear lights mounted above the counterweight are well protected.

8 The hydraulic hoses are routed within the main boom structure to guard against damage.



8

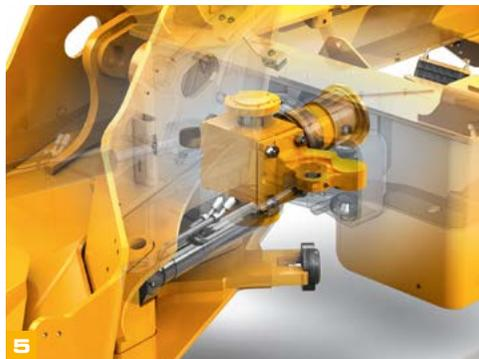

5



7



Widecore cooling pack with optional hydraulic reversing fan removes built-up debris. The reverse fan can be set to manual or automatic at the flick of a switch.

THE POWER TO PERFORM.

THE CLASS LEADER WHEN IT COMES TO LIFT CAPACITY AND TEAROUT FORCE, COMBINED WITH 5.2M LIFT HEIGHT, 2.9M FORWARD REACH AND THE SUPERB JCB ECOMAX ENGINE. THERE'S NOTHING THE TM320 CAN'T HANDLE.

JCB EcoMAX engine.

1 These machines feature our EcoMAX Tier 4 Final/Stage IV engine with variable geometry turbo, giving increased performance at low engine speed for improved cycle times and tractive effort. This 4.4 litre engine delivers a massive 550 Nm torque at low engine speeds for optimum response.



1

Traction and travel.

2 The JCB TM320 gives you ultimate traction and performance in soft, muddy ground, thanks to optional limited slip differentials and 4WD as standard.



2

3 Auto Smoothride System (SRS) engages at speeds of over 4mph/6kph. This improves load retention and comfort (and, in turn, productivity). The system can be manually engaged with the boom in any position. The SRS system is easily operated via a rocker switch. It can be auto-engaged by travel speed or constantly activated.

Our unique oscillating centre pivot point makes the most of traction by maintaining even weight distribution over each of the four wheels. It also gives extra stability and ride comfort.



3

Hydraulics and versatility.

- 4** The ability to change flow rate on-the-go is perfect for sweeper use, while the second boom auxiliary option caters for a wide range of twin auxiliary attachments.
- 5** 360 degree cab mounted and boom LED worklight options optimise visibility at night or in other darkened operating areas such as outbuildings, making 3am look like 3pm.
- 6** An additional benefit of the TM's articulated steering is the built-in sideshift which makes it easier to position attachments and place loads accurately.
- 7** The foot brake features a selectable transmission dump for superb multi-functioning control and increased engine speeds during loading or rehandling.
- 8** The TM320's variable flow auxiliary hydraulics are easy to use, designed to maximise productivity and efficiency. This flow sharing system with a variable flow piston pump also allows for multiple functions to be performed at the same time, reducing cycle times.

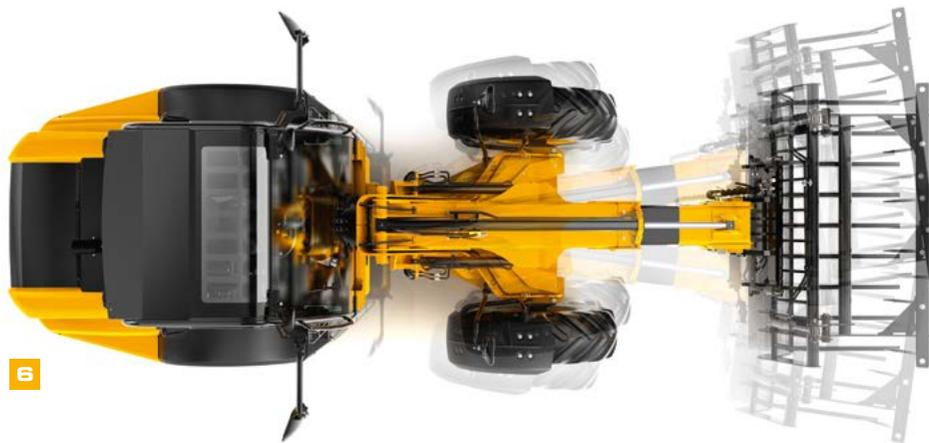

IN CONTROL, IN COMFORT.

THE TM320 MAKES LIFE EASIER. FIRST OF ALL, IT'S EASY TO OPERATE THANKS TO ERGONOMIC, INTUITIVE CONTROLS AND INTELLIGENT FEATURES. SECONDLY, IT PROVIDES A COMFORTABLE ENVIRONMENT TO WORK IN, MAKING OPERATORS MORE PRODUCTIVE.

At your command.

- 1 From the high, centrally mounted driving position you're in complete control, with a low boom pivot and large glass areas giving an unhampered 360° view.
- 2 Constant flow hydraulics are intuitive to use, with an in-cab display of the flow rate which can be adjusted on the go.
- 3 Manual transmission modes put the operator in control of increased transmission performance.

- 4 For ergonomic, fast and precise control, the TM320 is fitted with a fully proportional single lever mounted servo joystick controls. Joystick-mounted manual gear changes means you can shift gears, speed and direction quickly and easily with one ergonomic control.
- 5 Our new HVAC system keeps operators comfortable and focused for longer, the 3-speed fan heater can help create the perfect working temperature all year round. The optional air conditioning makes it even easier to find the best working temperature.

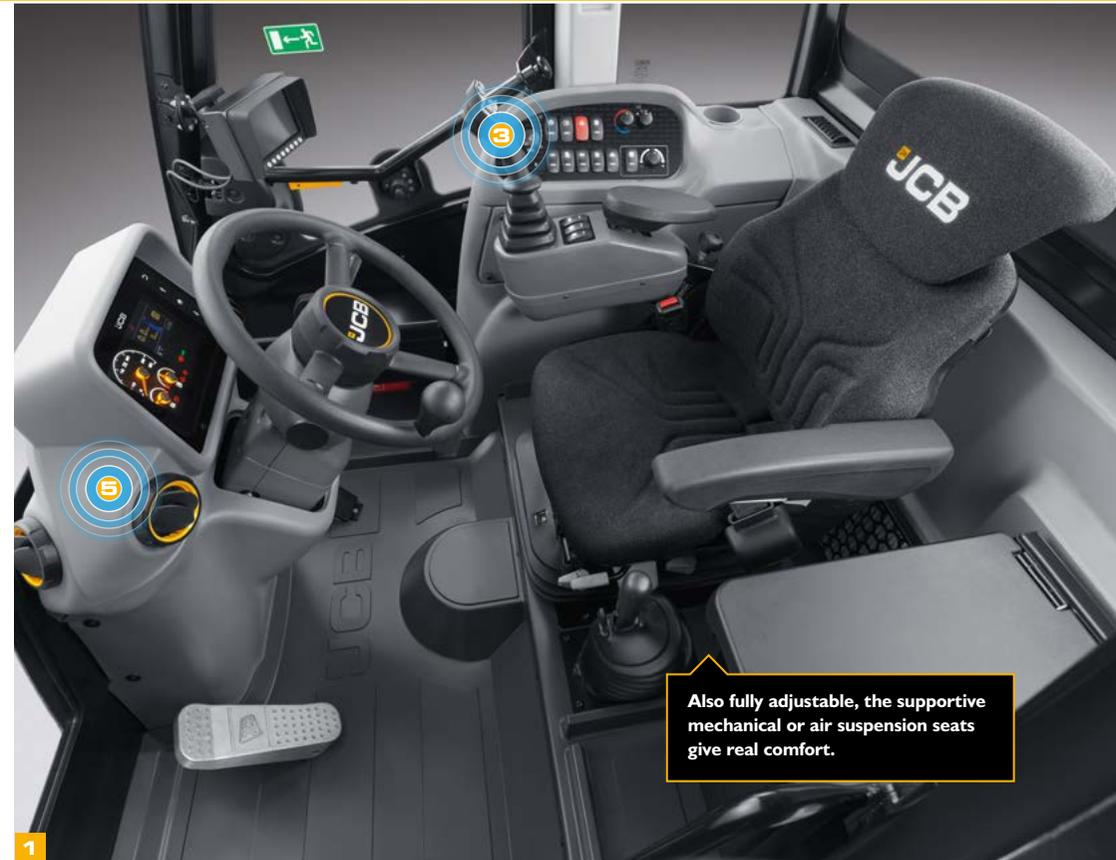

Sitting comfortably.

- 6 The cab is large and roomy with plenty of storage for home comforts and work essentials.
- 7 Boom end damping on lower and extend/retract reduces shock to the operator and the machine itself.
- 8 An LED colour dashboard relays useful information such as efficient running and fuel consumption figures, as well as displaying Diesel Exhaust Fluid (DEF) levels as well as in-cab daily checks. Constant flow hydraulics are intuitive to use, with the in-cab display of the flow rate, which can be adjusted on the go.
- 9 Backlit switches ensure quick and accurate control recognition, even in the dark.



SERVICING MADE EASY.

THE TM320 IS LOW MAINTENANCE AND EASY TO SERVICE, WHICH MEANS LESS DOWNTIME, AND MORE WORKING AND EARNING TIME. THEY'RE ALSO DESIGNED FOR CONSUMMATE SAFETY, PROTECTING BOTH YOU AND YOUR INVESTMENT.

Maintenance made easy.

1 Many competitor machines require a diesel particulate filter (DPF) to meet Tier 4 Final legislation. Instead, our machines use a sealed-for-life SCR system. The diesel & DEF (Diesel Exhaust Fluid) tanks are easily accessible as well as all daily check points which can all be carried out from ground level.

The wide-core single-faced cooling pack delivers maximum performance and lets small materials pass through. An optional reversing fan is available to allow simple and easy cleaning of the cooling pack.

A cyclonic air cleaner reduces debris build up in the air filter while an air intake scavenge system removes debris, extending service intervals.

2 The TM320's wide-opening rear bonnet gives clear access to service points, grease points are easily accessible and no tools are required to access the battery.

3 The TM320's self-lubricating boom wear pads and dry boom lubrication provides virtually maintenance-free operation. All greasing points have been extended to 500 hour intervals, courtesy of our graphite impregnated bronze bushes.



Keeping you safe.

- 4 Access steps are inclined and equally spaced, complemented by well positioned grab handles for three points of contact at all times.
- 5 Hose burst check valves on the rams prevent collapse if a hose fails.
- 6 The low boom profile and low boom pivot make for superb forward visibility.
- 7 Adaptive Load Control technology automatically controls hydraulic operation, helping to maintain the longitudinal stability of these machines.
- 8 Our in-cab, electronic 2-stage quickhitch isolation protects against accidental release of attachments.

- 9 In order to protect your investment, the TM320 is fitted with with JCB LiveLink telematics for real time vehicle tracking as standard.
- 10 Our optional rear-view camera displays an unobstructed rearward view on the in-cab colour monitor onboard your TM320.



8



9



10



New lock-back release door and offside window can be opened and closed from inside the cab.

A SMART INVESTMENT.

WHEN YOU OWN A JCB, YOU OWN A MACHINE THAT'S RENOWNED FOR HAVING HIGH RESIDUAL VALUES AROUND THE WORLD. COMBINED WITH EFFICIENT DESIGN THAT SAVES YOU MONEY, IT'S A REAL BUSINESS ASSET.



EcoMAX saves you money.

1 JCB's innovative Clean Burn technology helps our engines to meet Tier 4 Final/Stage IV regulations without exhaust after-treatments like DPFs. This means, of course, that costly DPF regeneration or costly replacement is never a worry.

Instead, the TM320 uses a sealed-for life Selective Catalytic Reduction (SCR) system. Among the numerous benefits of this setup is the fact that there's no loss of productivity due to DPF regeneration.

2 The TM320 is fitted with a 4 speed (3 speed on Wastemaster models) powershift transmission.



EcoMAX saves you money (cont.)

- 3 By producing high levels of power and torque even at engine speeds as low as 1300–1400rpm, EcoMAX can provide fuel-efficient matching of transmission and hydraulics.
- 4 The 93kW (125hp) JCB EcoMAX engine is fitted with a variable speed cooling fan that automatically reacts to ambient temperatures, adjusting fan speed to maximise fuel efficiency and in-cab noise.
- 5 High back-off power brakes reduce viscous drag during roading and rehandling, which improves fuel economy.
- 6 The TM320's load-sensing hydraulics only consume power on demand, conserving fuel.



LIVELINK, WORK SMARTER.

JCB LIVELINK IS AN INNOVATIVE SOFTWARE SYSTEM THAT LETS YOU MONITOR AND MANAGE YOUR MACHINES REMOTELY – ONLINE, BY EMAIL OR BY MOBILE PHONE.

Productivity and cost benefits –

Machine location information can improve fleet efficiency and you may even enjoy reduced insurance costs courtesy of the added security that LiveLink brings.

** Note: Please consult your local dealer for LiveLink availability*



Maintenance benefits – Accurate hours monitoring, maintenance history records, critical machine alerts and service alerts improve maintenance planning.

Security benefits – Real-time geofencing lets you set operating zones and curfew alerts that tell you when your machinery outside of pre-determined times. Location information helps you store machines safely.

VALUE ADDED.

JCB'S WORLDWIDE CUSTOMER SUPPORT IS FIRST CLASS. WHATEVER YOU NEED AND WHEREVER YOU ARE, WE'LL BE AVAILABLE QUICKLY AND EFFICIENTLY TO HELP MAKE SURE YOUR MACHINERY IS PERFORMING TO ITS FULL POTENTIAL.



1 Our Technical Support Service provides instant access to factory expertise, day or night, while our Finance and Insurance teams are always on hand to provide fast, flexible, competitive quotes.

JCB Assetcare offers comprehensive extended warranties and service agreements, as well as service-only or repair and maintenance contracts. Irrespective of what you opt for, our Maintenance teams around the world charge competitive labour rates, and offer non-obligation quotations as well as fast, efficient insurance repair work.



2 The global network of JCB Parts Centres is another model of efficiency; with 16 regional bases, we can deliver around 95% of all parts anywhere in the world within 24 hours. Our genuine JCB parts are designed to work in perfect harmony with your machine for optimum performance and productivity.

Note: JCB LIVELINK and JCB ASSETCARE may not be available in your region, so please check with your local dealer.

STATIC DIMENSIONS

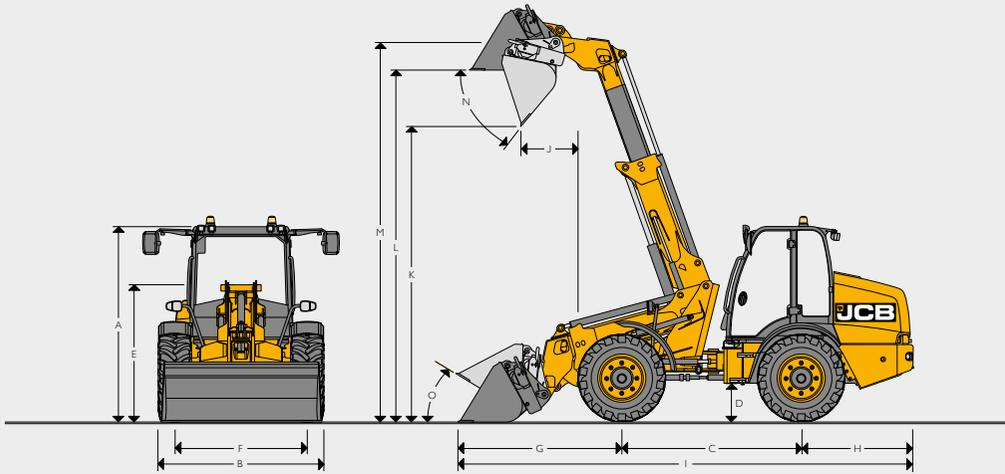

STATIC DIMENSIONS

A	Overall height	mm	2703
B	Overall width (over tyres)	mm	2350
C	Wheelbase	mm	2550
D	Ground clearance	mm	472
E	Height to top of boom pivot	mm	1835
F	Wheel track	mm	1870
G	Axle to shovel toe plate	mm	1627
H	Axle to counterweight face	mm	2143
I	Total length*	mm	6322
J	Dump reach	mm	933
K	Dump height	mm	4511
L	Load over height	mm	5182
M	Pin height	mm	5367
N	Maximum dump angle	degrees	39
O	Roll back at carry	degrees	41
	Total length to front of hitch	mm	5886
	Inside radius	mm	2001
	Outside radius (edge of tyre)	mm	4350
	Outside radius (over shovel)	mm	4633
	Articulation angle	degrees	± 43°
	Operating weight	kg	8160
	Front axle weight	kg	2730
	Rear axle weight	kg	5470
	Tyres used for specifications	Michelin BIBLOAD 460/70R24	
	Bucket used for specification	1 m ³ GP	
	Hitch used for specification	Pin & Cone	

*Please note total length: machine fitted with standard bucket – boom fully down, shovel crowded fully back.

ENGINE

Machine model	TM320 / TM320 Wastemaster		
Manufacturer	JCB		
Model	EcoMAX		
Capacity	ltr	4.4	
Bore	mm	103	
Stroke	mm	132	
Aspiration	Turbocharged/charge cooled		
Number of cylinders	4		
Power rating			
Gross power to SAE J1995/ISO 14396	kW (hp)	93 (125) @ 2200 rpm	
Net power to J1349/EEC 80/12	kW (hp)	86 (115) @ 2200rpm	
Torque rating			
Gross torque	Nm	550 @ 1500 rpm	

TRANSMISSION

Machine model	TM320	TM320 Wastemaster
Type	Powershift	Powershift
Make	JCB	JCB
Model	PS764 - 4 Speed	PS764 - 3 Speed
Max travel speed	kph	33
		20

AXLES

Machine model	TM320 / TM320 Wastemaster	
Type	Epicyclic hub reduction	
Make	JCB	
Model	Max-Trac	
Overall axle ratio/ drop box ratio	13.71	
Chassis angle oscillation	degrees	± 10°

BRAKES

Machine model	TM320 / TM320 Wastemaster	
Service brakes	In board oil immersed brakes	
Parking brake	Cable operated disc brake on transmissions output shaft	

NOISE AND VIBRATION

			Uncertainty	Measurement conditions.
Noise at the operator station	LpA	73 dB	+/- 1 dB	Determined in accordance with the test method defined in ISO 6396 and the dynamic test condition defined on 2000/14/EC.
Noise emission from the machine	LWA	107 dB	+/- 1 dB	Guaranteed equivalent sound power (external noise) determined in accordance with the dynamic test conditions defined in 2000/14/EC.
Whole body vibration	m/s ²	0.39	+/- 0.11 dB	ISO 2631-1:1997 normalised to an 8h reference period and based upon a test cycle comprising of loader work (soil).
Hand-arm vibration	m/s ²	<2.5	N/A	ISO 5349-2:2001 dynamic test conditions.

SERVICE FILL CAPACITIES

Machine model	TM320 / TM320 Wastemaster	
Hydraulic tank & transmission	litres	97
Fuel tank	litres	160
Engine oil sump	litres	14
Axle oil (front) including hubs	litres	20
Axle oil (rear) including hubs	litres	20
Drop box	litres	1.3
DEF	litres	29

HYDRAULICS

Machine model	TM320 / TM320 Wastemaster	
Pump type	Variable displacement piston pump	
Pump maximum flow	l/min	140
Pump maximum pressure	bar	230
Hydraulic cycle times		
Boom raise	seconds	5.5
Boom lower	seconds	6.0
Extend	seconds	3.5
Retract	seconds	2.7
Bucket dump	seconds	2.8
Bucket crowd	seconds	2.8
Total cycle time	seconds	23.3

ELECTRICAL SYSTEM

Machine model	TM320 / TM320 Wastemaster	
System voltage	Volt	12
Alternator output	Amp Hour	150
Battery capacity	Amp Hour	120

TYRE OPTIONS

Manufacturer	Size	Type	Application	Dimensional changes	
				Overall height (mm)	Width over tyres (mm)
Michelin	15.5R25	XHA	EM	-5	-86
Michelin	15.5R25	XTLA	EM	-9	-86
Michelin	12.0x24	X-MINED2	WASTE	31	-19
Michelin	12.0x24	XSM D2+	WASTE	26	-19
SG Revolution	13.0x24	SE	WASTE	26	-2

LOADER PERFORMANCE

Machine model	TM320 / TM320 Wastemaster	
Maximum lift capacity to full height with forks	kg	3200
Lift capacity at full reach	kg	1750
Lift height	mm	5200
Maximum forward reach	mm	2950
Straight tipping load - forks with 500mm load centre*		5262
Full turn tipping load - forks with 500mm load centre*	kg	4052 **
Full turn tipping load - forks calculated @ 80% load factor*	kg	3242 **
Full turn tipping load - forks calculated @ 60% load factor*	kg	2431 **
Breakout force - tearout	kg	6260

** Straight and Full Turn Tipping Load with forks and direct mount to Pin and Cone carriage to EN474 (ISO 14397)

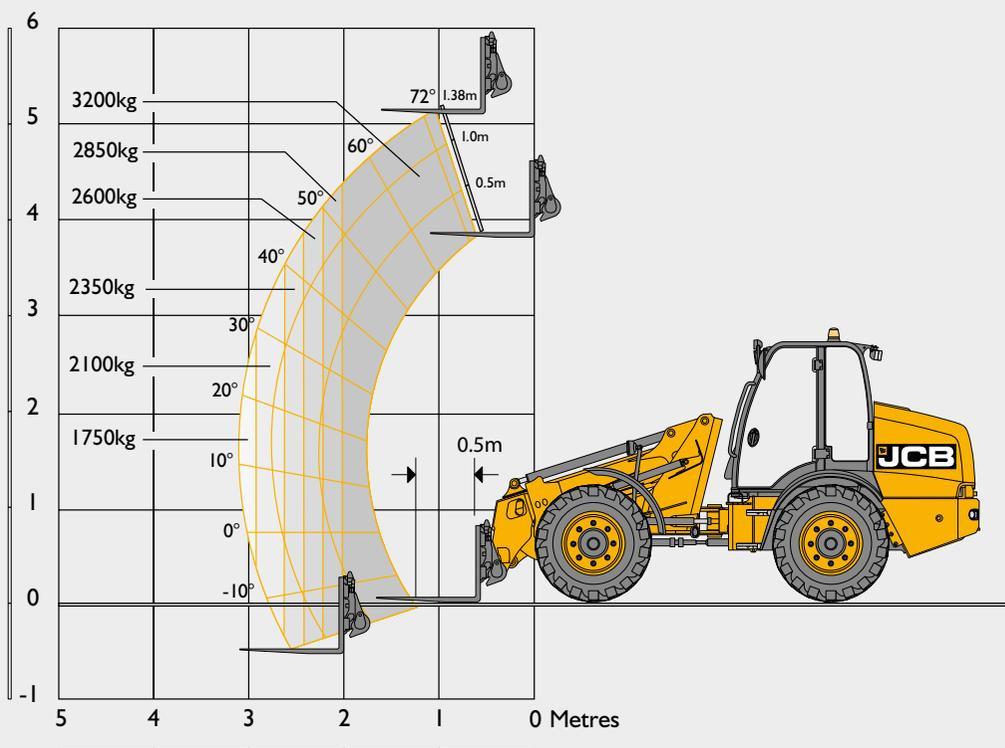

STANDARD/OPTIONAL EQUIPMENT

	TM320	TM320 WASTEMASTER		TM320	TM320 WASTEMASTER		TM320	TM320 WASTEMASTER
ENGINE AND COOLING			CAB			CHASSIS AND BODYWORK		
125hp JCB engine	•	•	ROPS/FOPS safety structure	•	•	Articulated steering	•	•
Cyclonic air filter	•	•	Laminated screen	•	•	Centre pivot oscillation	•	•
Air intake scavenge system	•	•	Fully adjustable mechanical seat	•	•	Plastic front and rear fenders	•	X
Widecore cooling pack	•	•	Air suspension seat	+	+	Fixed bottom step	•	•
Auto reversing fan	+	+	Interior light	•	•	Full width rear counterweight	•	•
			Tilt and telescopic steering column	•	•	Recovery hitch	•	•
TRANSMISSION / AXLES			Adjustable joystick control console and armrest	•	•	Prop shaft guard	•	•
4 speed Powershift transmission	•	X	Front and rear wash / wipe	•	•	Grease gun and cartridge	+	+
3-speed powershift	X	•	3 speed heater fan	•	•	Deluxe exterior mirrors	•	•
20kph travel speed	X	•	Air conditioning	+	+	Headlight guards	+	•
33kph travel speed	•	X	RH opening window with lock back	•	•	Front bumper	+	•
Transmissions disconnect on footbrake	•	•	LH opening door with door lock back	•	•	Steel front fenders	+	•
Forward / reverse controls on joystick	•	•	LH Sliding window	+	+			
Column mounted transmission selector	•	•	Single lever joystick controls	•	•	LOADER		
In board oil immersed disc brakes	•	•	Loader control isolator	•	•	Centre mounted single stage telescopic boom	•	•
Limited slip differentials front and rear	+	+	External rear view mirrors	•	•	Parallel lift	•	•
			Front and roof screen blinds	•	•	End damping on boom lower, extend and retract	•	•
HYDRAULICS			Fire extinguisher	+	+	Pin and Cone carriage (CAT III)	+	+
Servo controls	•	•	Additional storage box	+	+	JCB Q-fit carriage	+	+
Flow sharing hydraulics	•	•	Tool box	+	+	Industrial carriage	+	+
Proportional boom and auxiliary controls	•	•	Front screen guard	+	•	Electrical in cab quickhitch pin isolation	•	•
Adjustable constant flow hydraulics	•	•						
Variable displacement piston pump	•	•	ELECTRICAL			STANDARD •		
Priority steer valve	•	•	Road lights front and rear	•	•	OPTIONAL +		
Hose burst check valves	•	•	Reverse lights	•	•	NOT AVAILABLE X		
JCB Adaptive Load Control	•	•	Battery isolator	•	•	NB. Regional variations may apply to standard and optional equipment		
JCB Smoothride system	+	+	Direction indicators	•	•			
Biodegradable hydraulic oil	+	+	Rotating beacon	+	+			
			Twin beacons	+	+			
			Front and rear worklights	+	+			
			Boom worklights	+	+			
			Twin reverse light kit	+	+			
			Reverse foglight kit	+	+			
			LiveLink telematics	•	•			
			LED 360 degree worklights	+	+			
			12v in-cab power socket	•	•			
			Reverse camera with colour screen	+	+			



ONE COMPANY, OVER 300 MACHINES.

Your nearest JCB dealer

Telescopic Wheel Loader TM320 / TM320 Wastemaster

Gross power: TM320: 93kW (125hp)

Lift capacity: 3,200kg Lift height: 5,200mm

JCB Sales Limited, Rokeceter, Staffordshire, United Kingdom ST14 5JP.

Tel: +44 (0)1889 590312 Email: salesinfo@jcb.com

Download the very latest information on this product range at: www.jcb.com

©2009 JCB Sales. All rights reserved. No part of this publication may be reproduced, stored in a retrieval system, or transmitted in any form or by any other means, electronic, mechanical, photocopying or otherwise, without prior permission from JCB Sales. All references in this publication to operating weights, sizes, capacities and other performance measurements are provided for guidance only and may vary dependant upon the exact specification of machine. They should not therefore be relied upon in relation to suitability for a particular application. Guidance and advice should always be sought from your JCB Dealer. JCB reserves the right to change specifications without notice. Illustrations and specifications shown may include optional equipment and accessories. All images are correct at time of print. The JCB logo is a registered trademark of J C Bamford Excavators Ltd.

